



## DRAWING INDEX

### ARCHITECTURAL DRAWINGS

- A-00 ZONING SUMMARY
- A-01 SITE PLAN FOR BOTH LOTS
- A-02 FLOOR PLANS - BASEMENT BOTH LOTS
- A-03 FLOOR PLANS - MAIN BOTH LOTS
- A-04 FLOOR PLANS - UPPER BOTH LOTS
- A-05 ROOF PLANS - BOTH LOTS
- A-06 FRONT ELEVATIONS (BOTH HOUSES)
- A-07 REAR ELEVATIONS (BOTH HOUSES)
- A-08 SIDE ELEVATIONS (LOT A)
- A-09 SIDE ELEVATION (LOT B)
- A-10 BUILDING SECTIONS - LOT A
- A-11 BUILDING SECTIONS - LOT B
- A-12 ACCESSORY BUILDING

### LANDSCAPE

- L-00 TREE PROTECTION PLAN
- L-01 LANDSCAPE PLAN + PLANTING LIST

## SUBDIVISION & REZONING APPLICATION

**HOMES ON TWENTY FIRST**  
**540 WEST 21st STREET, NORTH VANCOUVER**

**Legal Address: LOT 28, BLOCK 202, DL. 544, PLAN 1364**  
**PID:014-767-805**

**OWNER: 1360896 BC LTD.**

**APPLICANT: VERNACULAR STUDIO INC.**

**ISSUED FOR: REZONING & SUBDIVISION RESUBMISSION [JUNE 17, 2024]**

**PROJECT SYNOPSIS**

Current Lot Area: 15.85M x 42.95M = 680.75 SM [50' X 141' = 7,046 SF]  
 Current Zoning: RS1  
 Proposed Zoning: RS2 (with minimum lot size relaxation)  
 As minimum lot size is 334.45 SM (3,600 SF) lot area. Ref. Bylaw 506 (1)d  
 Proposed FSR: 0.50 for each lot  
 Subdivision: From one lot to two lots of 15.22 M. (25 FT) wide

**PROPOSED PROJECT SUMMARY IS FOR SUBDIVISION AND REZONING**

**Lot A (WEST)**

Lot Area: 7.62 X 42.97 = 327.43 SM  
 25.0' X 141.0'= 3,523 SF

FSR Allowed: (0.50)327.43 X 0.5 = 163.71 SM1,761.5 SF.  
 FSR Proposed: 163.60 SM1,761.0 SF.

Main Floor: 78.60 SM [931.0 SF]  
 Upper: 77.10 SM [830.0 SF]  
 Basement: (79.06 SM [966.0 SF])  
 Total Lot A: 158.03 SM [1,761.0 SF]

SETBACKS:	ALLOWED	PROPOSED
FRONT:	4.57 M (15')	6.70 M (22.0')
REAR: 35% LOT DEPTH	15.04 M (49.35')	16.69 M (54.75')
EAST SIDE:	1.2 M (4')	1.2 M (4')
WEST SIDE:	1.2 M (4')	1.2 M (4')
House to Garage:	3.0 M. (10')	N/A
Lot Coverage:	30%	30%
Accessory Building:	10% 32.73 SM [352.3 SF]	32.73 SM [352.3 SF]
Parking:	2	1
SECONDARY SUITE: 40%	65.44 SM [704.4 SM]	34% 55.62 (600.0 SF)
Parking for Suite:	One	NONE
Bike:	2 Enclosed	2 Enclosed

**Lot A (WEST)**

Lot Area: 7.62 X 42.97 = 327.43 SM  
 25.0' X 141.0'= 3,523 SF

FSR Allowed: (0.50)327.43 X 0.5 = 163.71 SM1,761.5 SF.  
 FSR Proposed: 163.60 SM1,761.0 SF.

Main Floor: 78.60 SM [931.0 SF]  
 Upper: 77.10 SM [830.0 SF]  
 Basement: (79.06 SM [966.0 SF])  
 Total Lot A: 158.03 SM [1,761.0 SF]

SETBACKS:	ALLOWED	PROPOSED
FRONT:	4.57 M (15')	6.70 M (22.0')
REAR: 35% LOT DEPTH	15.04 M (49.35')	16.69 M (54.75')
EAST SIDE:	1.2 M (4')	1.2 M (4')
WEST SIDE:	1.2 M (4')	1.2 M (4')
House to Garage:	3.0 M. (10')	N/A
Lot Coverage:	30%	30%
Accessory Building:	10% 32.73 SM [352.3 SF]	32.73 SM [352.3 SF]
Parking:	2	1
SECONDARY SUITE: 40%	65.44 SM [704.4 SM]	34% 55.62 (600.0 SF)
Parking for Suite:	One	NONE
Bike:	2 Enclosed	2 Enclosed

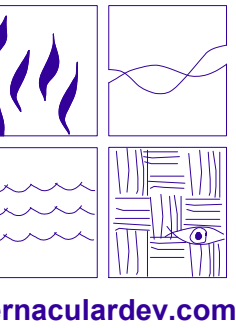

**COPYRIGHT:**  
 THIS PLAN AND DESIGN ARE AND AT ALL TIMES THE EXCLUSIVE PROPERTY OF VERNACULAR STUDIO INC. AND MAY NOT BE REUSED, REPRODUCED, AND REVISED WITHOUT PRIOR WRITTEN CONSENT.

PROJECT:

540 WEST 21st STREET,  
NORTH VANCOUVER

DRAWING TITLE:

PROJECT SUMMARY /  
ZONING SUMMARY

DATE:

JUNE 17, 2024

DRAWING NO. :

A-00

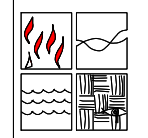

300-120 Lonsdale Ave  
North Vancouver, B.C  
V7M 2E8  
Phone: (604)990-6662  
Web: vernaculardev.ca

**SITE COVERAGE (MAIN HOUSE): 1056.0 SF.**  
**SITE COVERAGE (ACCESSORY BUILDING): 352.0 SF.**

**CONSULTANTS:**

**COPYRIGHT:**  
THIS PLAN AND DESIGN ARE AND AT ALL TIMES THE EXCLUSIVE PROPERTY OF VERNACULAR STUDIO INC. AND MAY NOT BE REUSED, REPRODUCED, AND REVISED WITHOUT PRIOR WRITTEN CONSENT.

**GENERAL NOTES:**  
THIS DRAWING MUST NOT BE SCALED. THE GENERAL CONTRACTOR SHALL VERIFY ALL DIMENSIONS AND LEVELS PRIOR TO COMMENCEMENT OF WORK. ALL ERRORS AND OMISSIONS SHALL BE REPORTED IMMEDIATELY TO VERNACULAR STUDIO INC.

LOCATION OF ACCESSORY BUILDING IS SUBJECT TO THE TREE & MINIMUM REQUIRED DISTANCE BTWN. TWO BLDGDS.

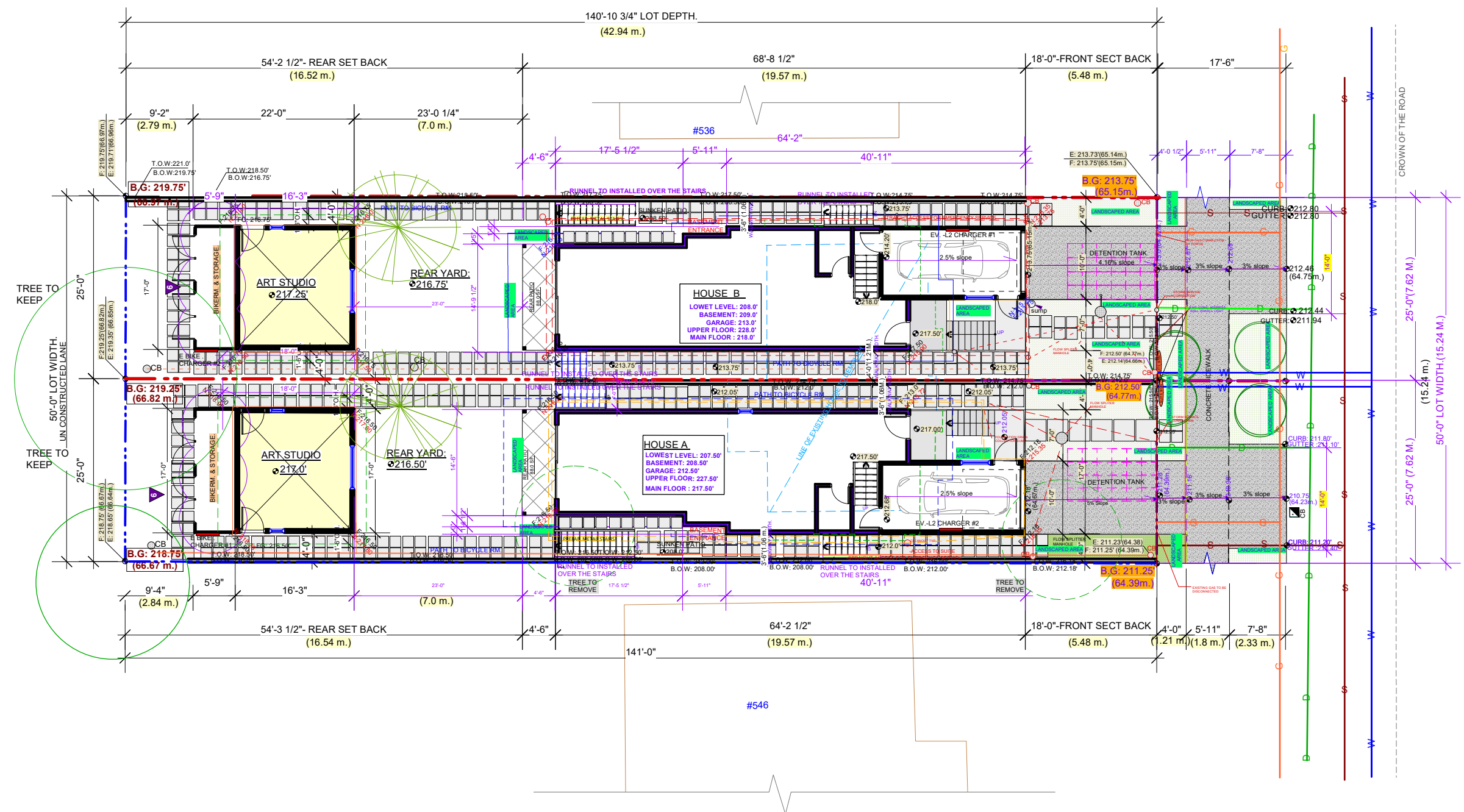

WEST 21TH ST.

F: (FINISHED GRADE)  
E: (EXISTING GRADE)

- ⊙ POWER VENT
- ⊕ FLOOR DRAIN
- ⊗ SMOKE ALARM
- ⊙ FINISHED ELEVATION



REVISION:

No.	Issue for	DATE
9		
8		
7	SUBDIV/REZ	JUNE 14, 2024
6	SUBDIV/REZ	FEB. 07, 2024
5	SUBDIV/REZ	OCT. 25, 2023
4	SUBDIV/REZ.	AUG. 29, 2023
3	SUBDIV/REZ.	APRIL 06 2023
2	SUBDIV/REZ.	SEP 23, 2022
1	PRE-APP.	APRIL 05 2022

PROJECT:

**540 WEST 21TH ST.**

DRAWING TITLE:

**SITE PLAN**

DATE:

JUNE.04. 2024

DRAWING NO.:

**A-01**

DRAWN BY :

-G.A.

CHECKED BY:

-M.R.

-R.CH

SCALE: 1/16"



CONSULTANTS:

**COPYRIGHT:**  
THIS PLAN AND DESIGN ARE AND AT ALL TIMES THE EXCLUSIVE PROPERTY OF VERNACULAR STUDIO INC. AND MAY NOT BE REPRODUCED, REPRODUCED, AND REVISED WITHOUT PRIOR WRITTEN CONSENT.

**GENERAL NOTES:**  
THIS DRAWING MUST NOT BE SCALED. THE GENERAL CONTRACTOR SHALL VERIFY ALL DIMENSIONS AND LEVELS PRIOR TO COMMENCEMENT OF WORK. ALL ERRORS AND OMISSIONS SHALL BE REPORTED IMMEDIATELY TO VERNACULAR STUDIO INC.

LEGEND:

- F: (FINISHED GRADE)
- E: (EXISTING GRADE)
- ⊙ POWER VENT
- ⊕ FLOOR DRAIN
- ⊗ SMOKE ALARM
- ⊕ FINISHED ELEVATION



REVISION:

No.	Issue for	DATE
9		
8		
7	SUBDIV/REZ.	June 14, 2024
6	SUBDIV/REZ.	FEB. 07, 2024
5	SUBDIV/REZ.	OCT. 25, 2023
4	SUBDIV/REZ.	AUG. 29, 2023
3	SUBDIV/REZ.	APRIL 06, 2023
2	SUBDIV/REZ.	SEP 23, 2022
1	PRE-APP.	APRIL 05 2022

PROJECT:

**540  
WEST 21TH ST.**

DRAWING TITLE:

**BASEMENT PLAN**

DATE:

JUNE 2019

DRAWING NO.:

DRAWN BY:

-G.A.

CHECKED BY:

-M.R.

-R.CH

SCALE: 1/8

**A-02**

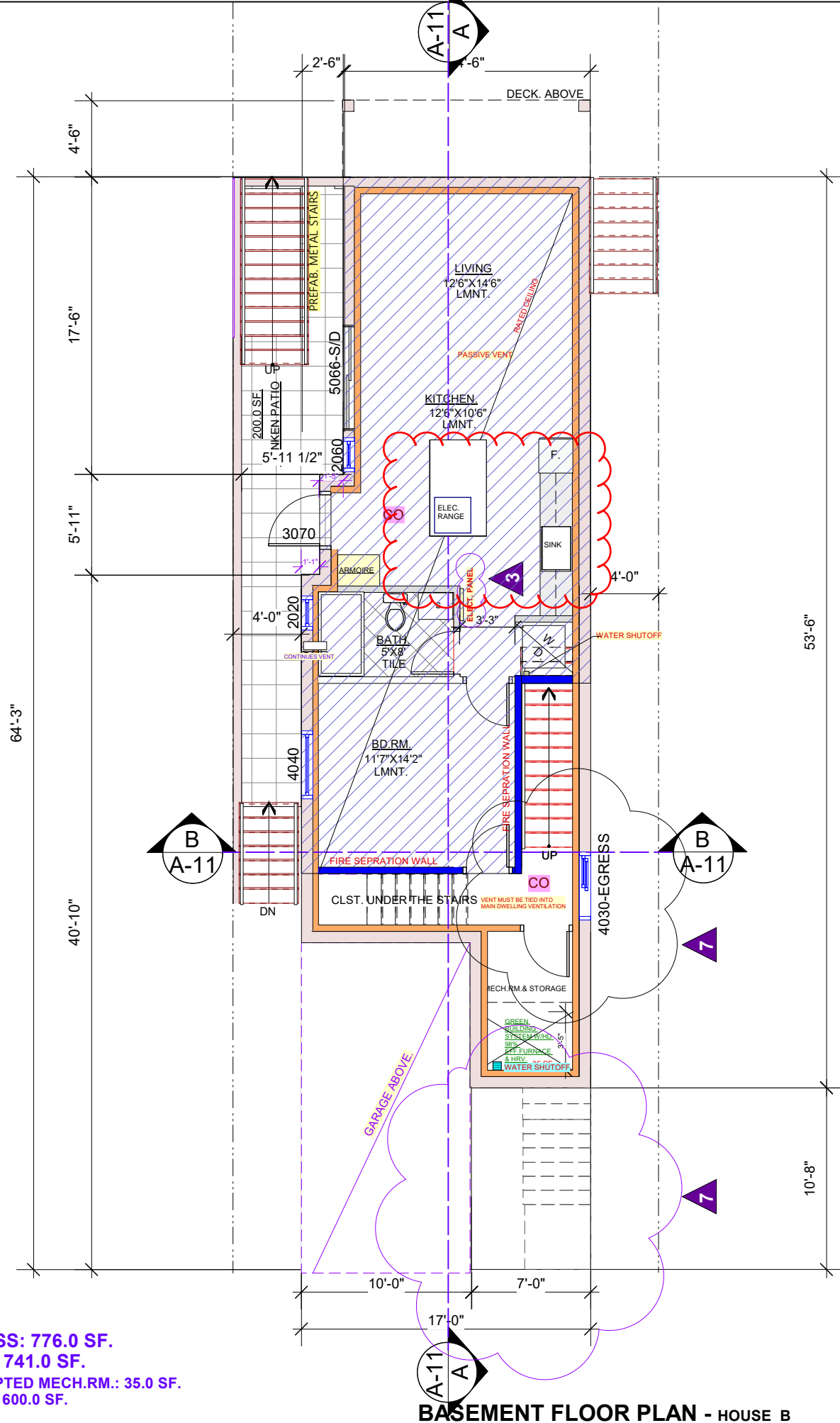

SECONDARY SUITE : 600.0 SF.

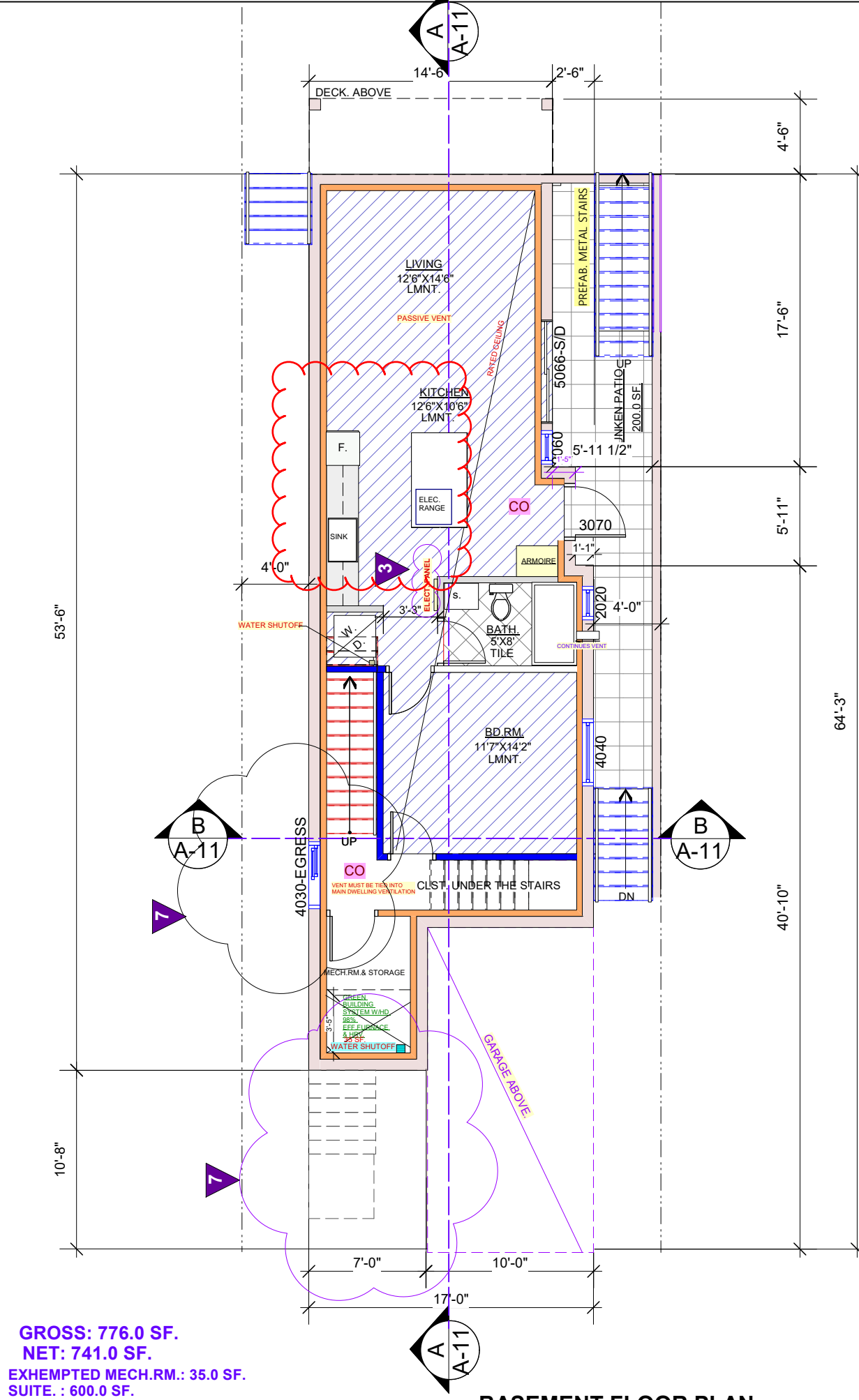

SECONDARY SUITE : 600.0 SF.

CONSULTANTS:

**COPYRIGHT:**  
THIS PLAN AND DESIGN ARE AT ALL TIMES THE EXCLUSIVE PROPERTY OF VERNACULAR STUDIO INC. AND MAY NOT BE REPRODUCED, REPRODUCED, AND REVISED WITHOUT PRIOR WRITTEN CONSENT.

**GENERAL NOTES:**  
THIS DRAWING MUST NOT BE SCALED. THE GENERAL CONTRACTOR SHALL VERIFY ALL DIMENSIONS AND LEVELS PRIOR TO COMMENCEMENT OF WORK. ALL ERRORS AND OMISSIONS SHALL BE REPORTED IMMEDIATELY TO VERNACULAR STUDIO INC.

LEGEND:

- F: (FINISHED GRADE)
- E: (EXISTING GRADE)
- POWER VENT
- FLOOR DRAIN
- SMOKE ALARM
- FINISHED ELEVATION

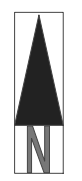

REVISION:

No.	Issue for	DATE
9		
8		
7	SUBDIV/REZ.	June 14, 2024
6	SUBDIV/REZ.	FEB. 07, 2024
5	SUBDIV/REZ.	OCT. 25, 2023
4	SUBDIV/REZ.	AUG. 29, 2023
3	SUBDIV/REZ.	APRIL 06, 2023
2	SUBDIV/REZ.	SEP 23, 2022
1	PRE-APP.	APRIL 05 2022

PROJECT:

**540 WEST 21TH ST.**

DRAWING TITLE:

**MAIN PLAN**

DATE:  
JUNE 2019

DRAWN BY:  
-G.A.

CHECKED BY:  
-M.R.

-R.CH

SCALE: 1/8"

**A-03**

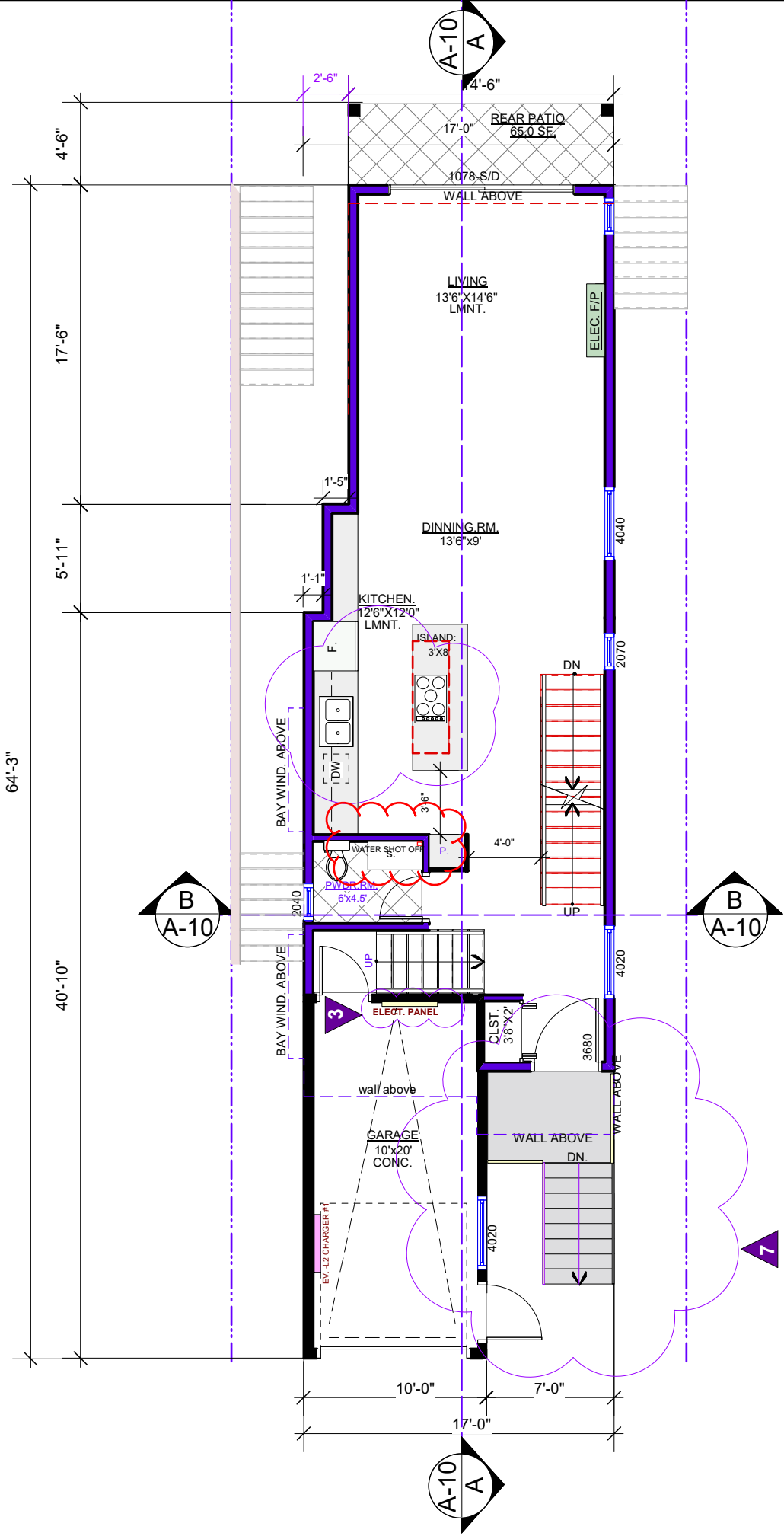

**MAIN FLOOR PLAN- HOUSE A**

**931.0 SF.**

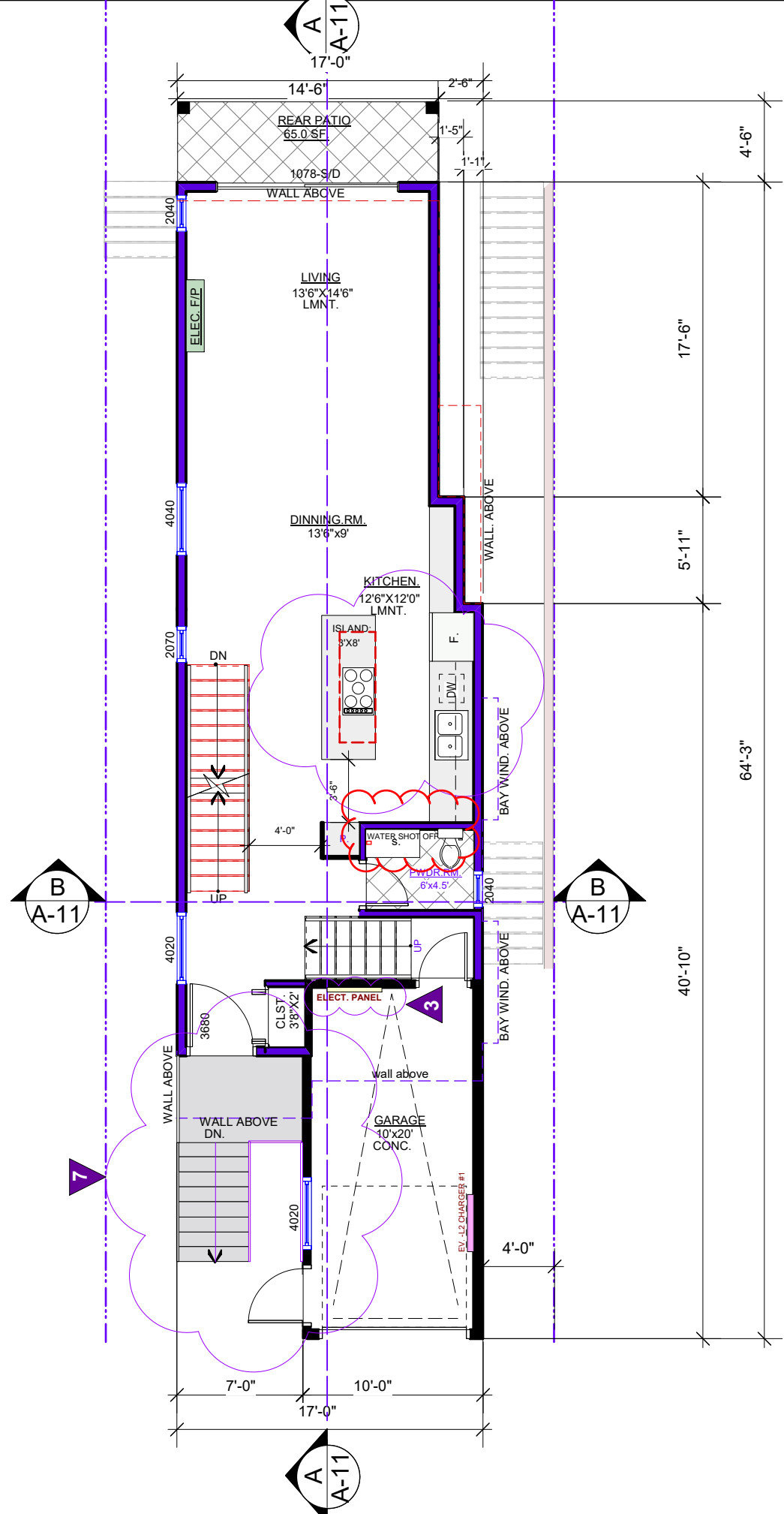

**MAIN FLOOR PLAN - HOUSE B**

**931.0 SF.**

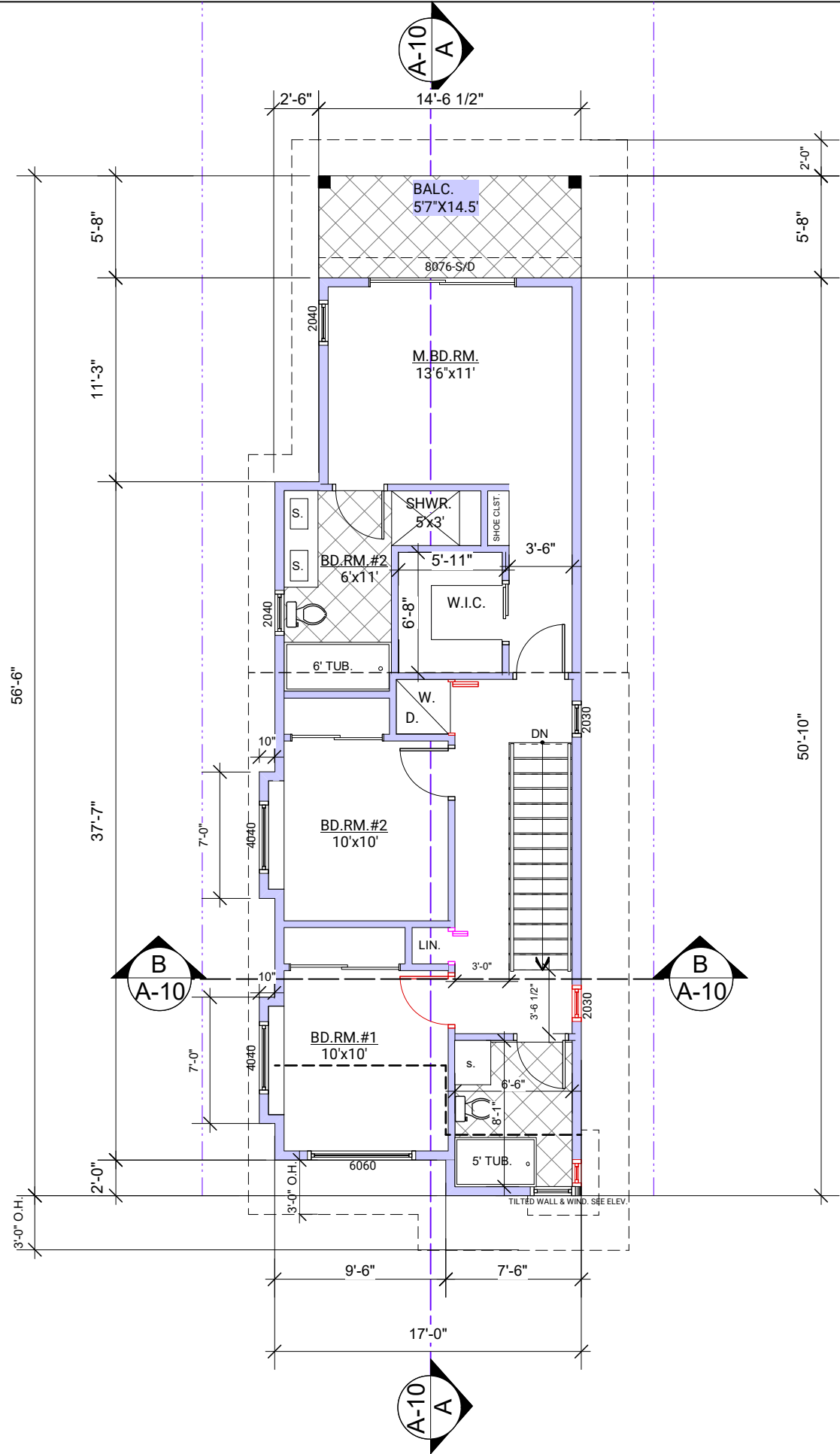

UPPER FLOOR PLAN- HOUSE A

828.0 SF.

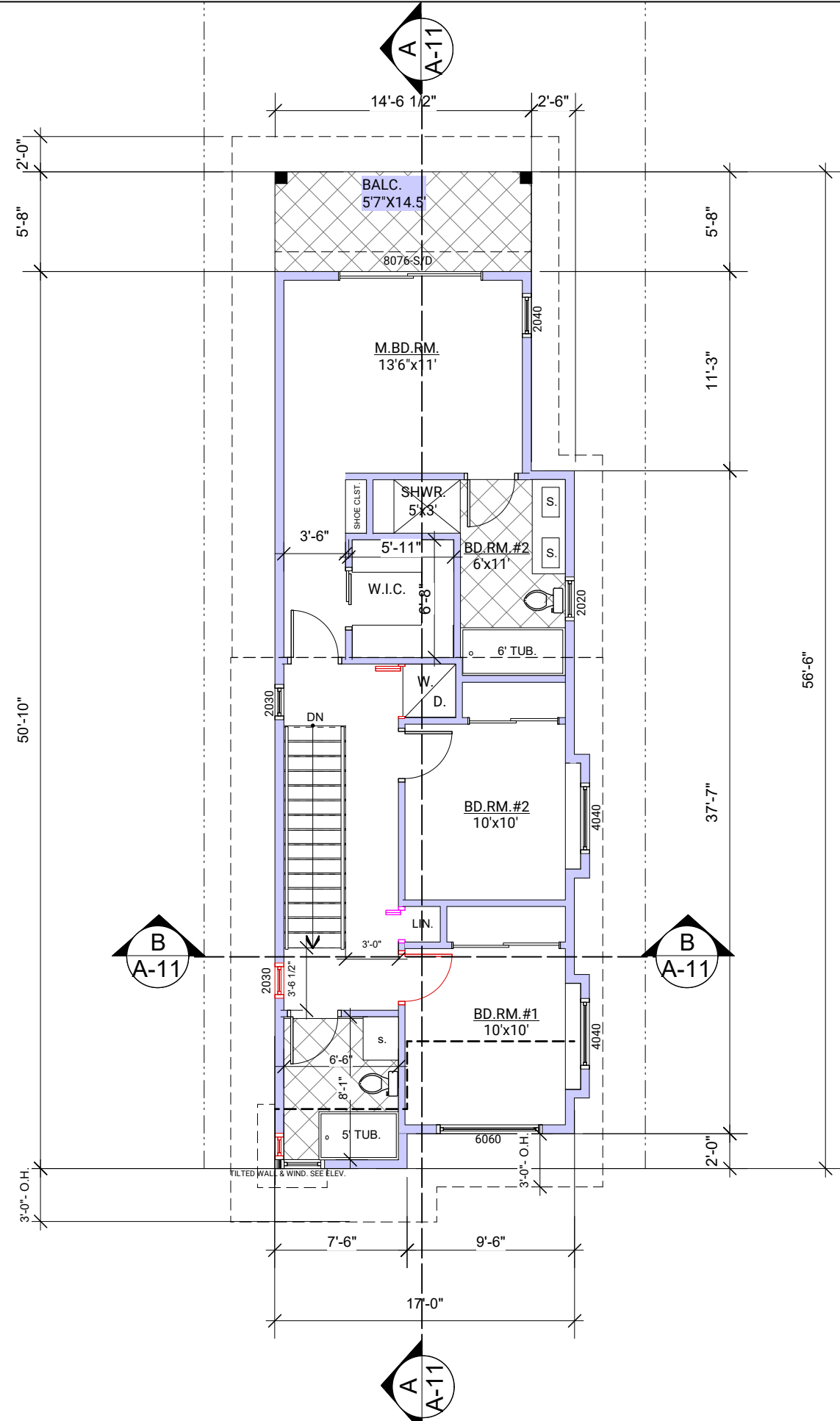

UPPER FLOOR PLAN - HOUSE B

828.0 SF.

**CONSULTANTS:**

**COPYRIGHT:**  
THIS PLAN AND DESIGN ARE AND AT ALL TIMES THE EXCLUSIVE PROPERTY OF VERNACULAR STUDIO INC. AND MAY NOT BE REUSED, REPRODUCED, AND REVISED WITHOUT PRIOR WRITTEN CONSENT.

**GENERAL NOTES:**  
THIS DRAWING MUST NOT BE SCALED. THE GENERAL CONTRACTOR SHALL VERIFY ALL DIMENSIONS AND LEVELS PRIOR TO COMMENCEMENT OF WORK. ALL ERRORS AND OMISSIONS SHALL BE REPORTED IMMEDIATELY TO VERNACULAR STUDIO INC.

- LEGEND:**
- F: (FINISHED GRADE)
  - E: (EXISTING GRADE)
  - POWER VENT
  - FLOOR DRAIN
  - SMOKE ALARM
  - FINISHED ELEVATION



**REVISION:**

No.	Issue for	DATE
9		
8		
7	SUBDIV/REZ.	June 14, 2024
6		
5	SUBDIV/REZ.	OCT. 25, 2023
4	SUBDIV/REZ.	AUG. 29, 2023
3	SUBDIV/REZ.	APRIL 06, 2023
2	SUBDIV/REZ.	SEP 23, 2022
1	PRE-APP.	APRIL 05 2022

**PROJECT:**

**540 WEST 21TH ST.**

**DRAWING TITLE:**

**UPPER FLOOR PLAN**

**DATE:** JUNE 2019

**DRAWN BY:** -G.A.

**CHECKED BY:** -M.R.

-R.CH

**SCALE:** 1/8

**A-04**

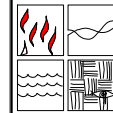

**CONSULTANTS:**

**COPYRIGHT:**  
THIS PLAN AND DESIGN ARE AND AT ALL TIMES  
THE EXCLUSIVE PROPERTY OF VERNACULAR  
STUDIO INC. AND MAY NOT BE REUSED,  
REPRODUCED, AND REVISED WITHOUT  
PRIOR WRITTEN CONSENT.

**GENERAL NOTES:**  
THIS DRAWING MUST NOT BE SCALED. THE  
GENERAL CONTRACTOR SHALL VERIFY ALL  
DIMENSIONS AND LEVELS PRIOR TO  
COMMENCEMENT OF WORK. ALL  
ERRORS AND OMISSIONS SHALL BE REPORTED  
IMMEDIATELY TO VERNACULAR STUDIO INC.

**LEGEND:**

F: (FINISHED GRADE)  
E: (EXISTING GRADE)

- POWER VENT
- FLOOR DRAIN
- SMOKE ALARM
- FINISHED ELEVATION



**REVISION:**

NO.	ISSUE FOR	DATE
9		
8		
7	SUBDIV/REZ.	June 14, 2024
6		
5	SUBDIV/REZ.	OCT. 25, 2023
4	SUBDIV/REZ.	AUG. 29, 2023
3	SUBDIV/REZ.	APRIL 06, 2023
2	SUBDIV/REZ.	SEP 23, 2022
1	PRE-APP.	APRIL 05 2022

**PROJECT:**

**540 WEST 21TH ST.**

**DRAWING TITLE:**

**ROOF PLAN**

**DATE:**  
JUNE 2019

**DRAWING NO.:**

**DRAWN BY:**  
-G.A.

**CHECKED BY:**  
-M.R.

-R.CH

**SCALE:** 1/8

**A-05**

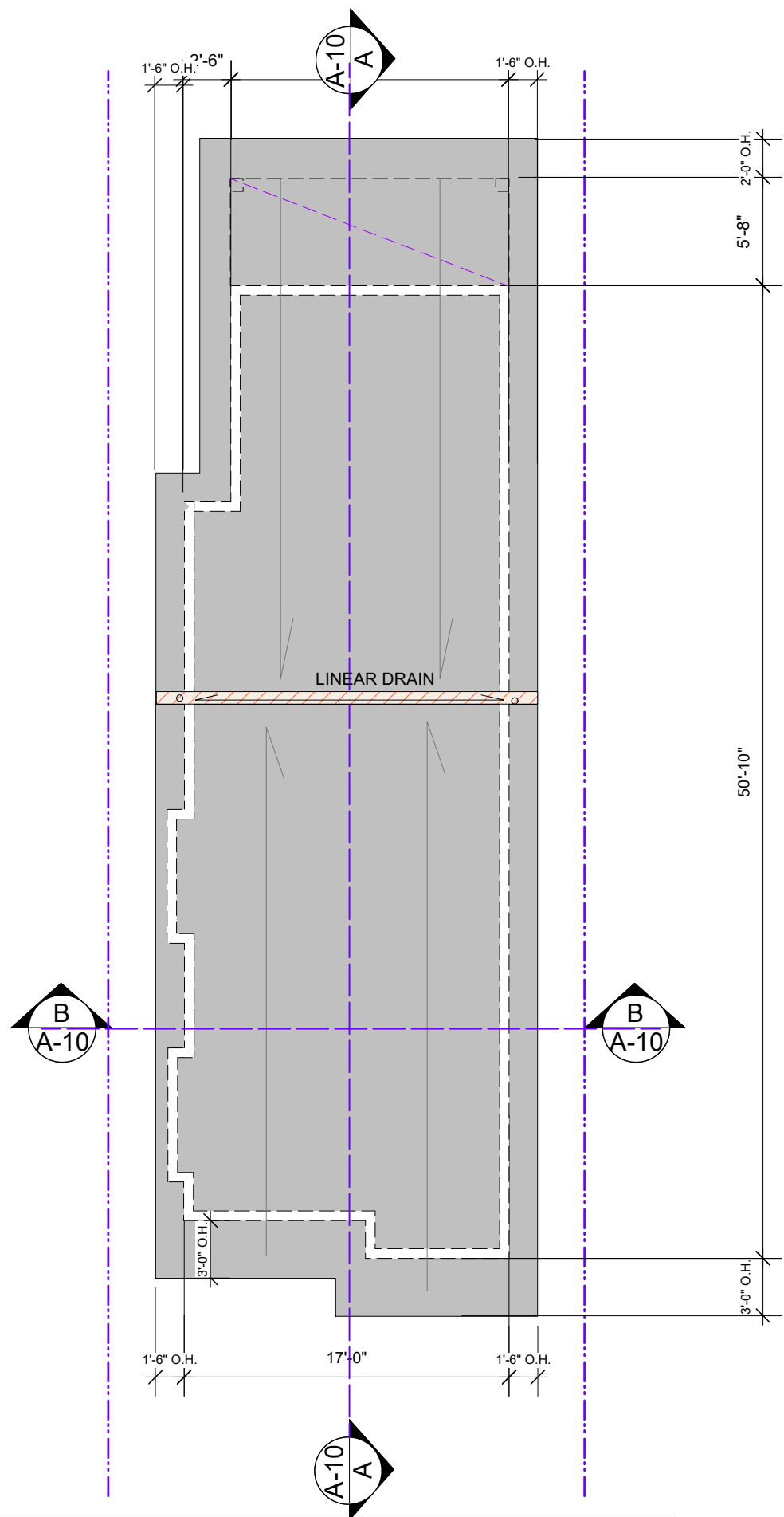

**ROOF PLAN, HOUSE A**

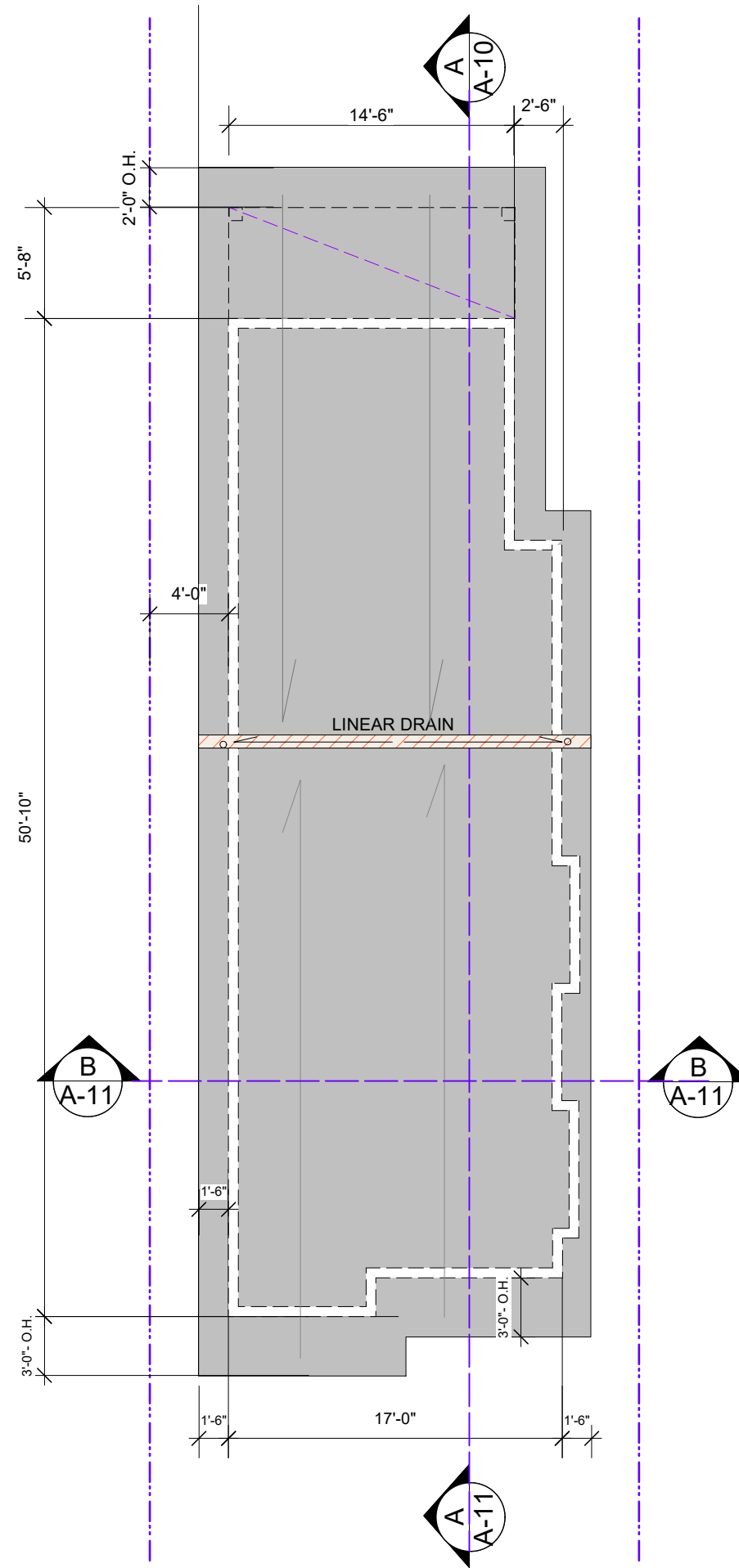

**ROOF PLAN , HOUSE B**

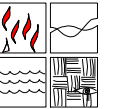

**CONSULTANTS:**

**COPYRIGHT:**  
THIS PLAN AND DESIGN ARE AND AT ALL TIMES THE EXCLUSIVE PROPERTY OF VERNACULAR STUDIO INC. AND MAY NOT BE REUSED, REPRODUCED, AND REVISED WITHOUT PRIOR WRITTEN CONSENT.

**GENERAL NOTES:**  
THIS DRAWING MUST NOT BE SCALED. THE GENERAL CONTRACTOR SHALL VERIFY ALL DIMENSIONS AND LEVELS PRIOR TO COMMENCEMENT OF WORK. ALL ERRORS AND OMISSIONS SHALL BE REPORTED IMMEDIATELY TO VERNACULAR STUDIO INC.

**LEGEND:**

- F: (FINISHED GRADE)
- E: (EXISTING GRADE)
- ⊙ POWER VENT
- ⊕ FLOOR DRAIN
- ⊗ SMOKE ALARM
- ⊕ FINISHED ELEVATION

**REVISION:**

No.	Issue for	DATE
9		
8		
7	SUBDIV/REZ.	June 14, 2024
6	SUBDIV/REZ.	FEB. 07, 2024
5	SUBDIV/REZ.	OCT. 25, 2023
4	SUBDIV/REZ.	AUG. 29, 2023
3	SUBDIV/REZ.	APRIL 06, 2023
2	SUBDIV/REZ.	SEP 23, 2022
1	PRE-APP.	APRIL 05 2022

**PROJECT:**

**540 WEST 21TH ST.  
HOUSE 'A' & 'B'**

**DRAWING TITLE:**

**FRONT ELEVATIONS**

**DATE:**  
JUNE 2019

**DRAWING NO.:**

**DRAWN BY:**  
-G.A.

**CHECKED BY:**  
-M.R.

-R.CH

**SCALE:** 1/8

**A-06**





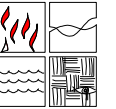

**CONSULTANTS:**

**COPYRIGHT:**  
THIS PLAN AND DESIGN ARE AND AT ALL TIMES THE EXCLUSIVE PROPERTY OF VERNACULAR STUDIO INC. AND MAY NOT BE REPRODUCED, REPRODUCED, AND REVISED WITHOUT PRIOR WRITTEN CONSENT.

**GENERAL NOTES:**  
THIS DRAWING MUST NOT BE SCALED. THE GENERAL CONTRACTOR SHALL VERIFY ALL DIMENSIONS AND LEVELS PRIOR TO COMMENCEMENT OF WORK. ALL ERRORS AND OMISSIONS SHALL BE REPORTED IMMEDIATELY TO VERNACULAR STUDIO INC.

**LEGEND:**

F: (FINISHED GRADE)  
E: (EXISTING GRADE)

POWER VENT

FLOOR DRAIN

SMOKE ALARM

FINISHED ELEVATION

**REVISION:**

No.	Issue for	DATE
9		
8		
7	SUBDIV/REZ.	June, 14, 2024
6		
5	SUBDIV/REZ.	OCT. 25, 2023
4	SUBDIV/REZ.	AUG. 29, 2023
3	SUBDIV/REZ.	APRIL 06, 2023
2	SUBDIV/REZ.	SEP 23, 2022
1	PRE-APP.	APRIL 05 2022

**PROJECT:**

**540 WEST 21TH ST.  
HOUSE 'A' & 'B'**

**DRAWING TITLE:**

**REAR ELEVATIONS**

**DATE:**  
JUNE 2019

**DRAWING NO.**

**DRAWN BY:**  
-G.A.

**CHECKED BY:**  
-M.R.

-R.CH

**SCALE:** 1/8

**A-07**

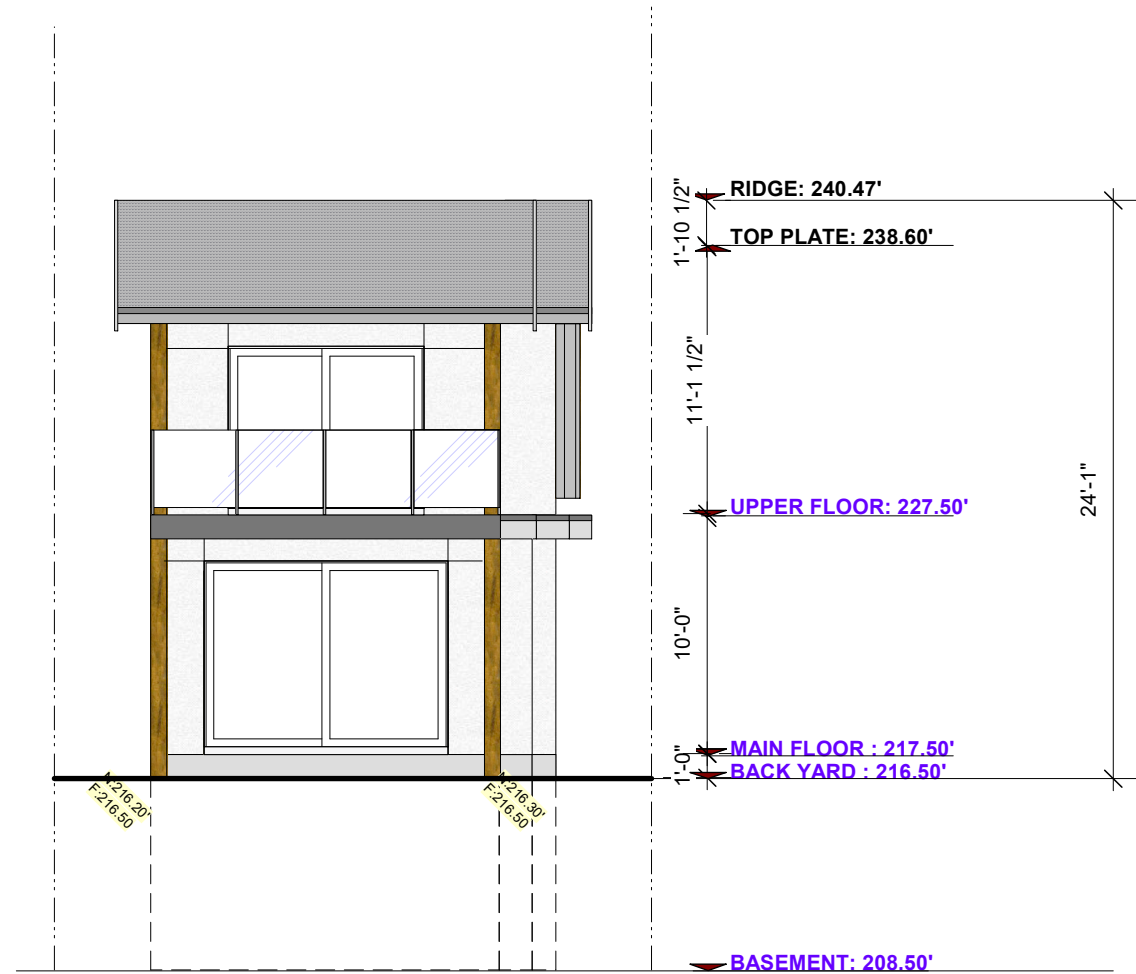

**SOUTH ELEVATION - HOUSE A**

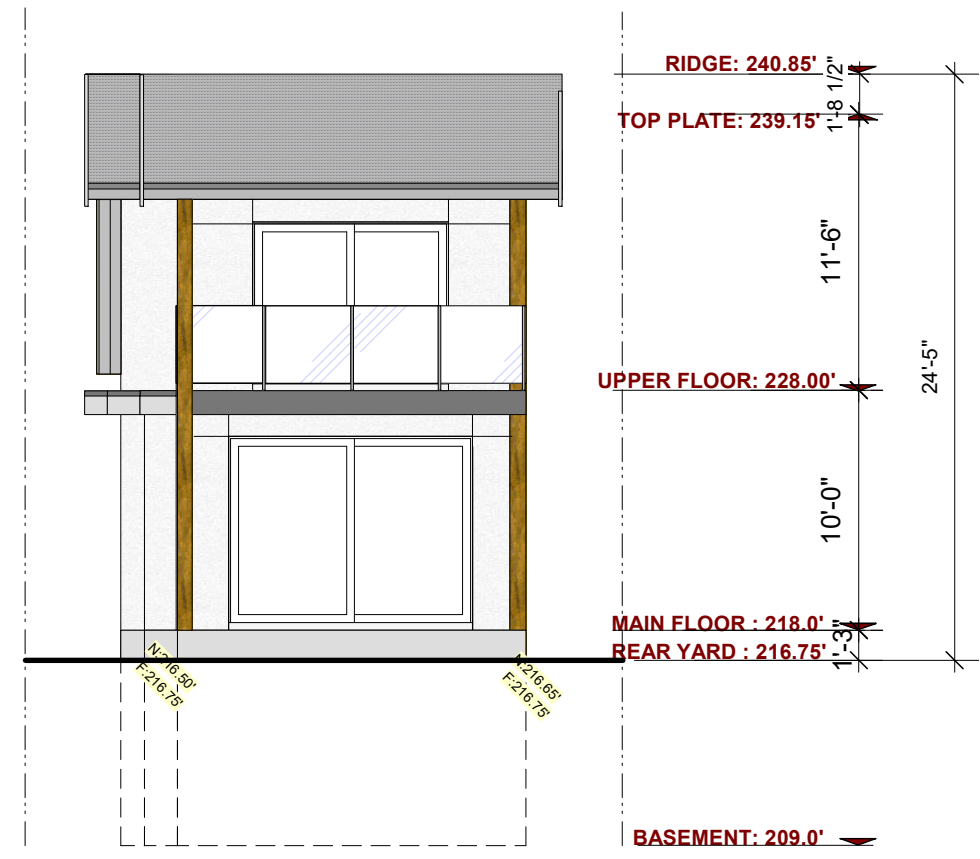

**SOUTH ELEVATION - HOUSE B**

7

**UNPROTECTED OPENINGS EAST ELEVATION**

WALL AREA=1409.0 SF. (130.90 S.M.)  
LIMITING DISTANCE=4'0" (1.2 M)  
PERMITTED U.P.O.(7%)=98.63 S.F.  
PROPOSED=87.65 SQ.FT. (8.14 S.M.)



**WEST ELEVATION - HOUSE A**

ALLOWABLE RIDGE: 247.60'

ALLOWABLE TOP PLATE: 240.80'

PROPOSED TOP PLATE: 238.60'

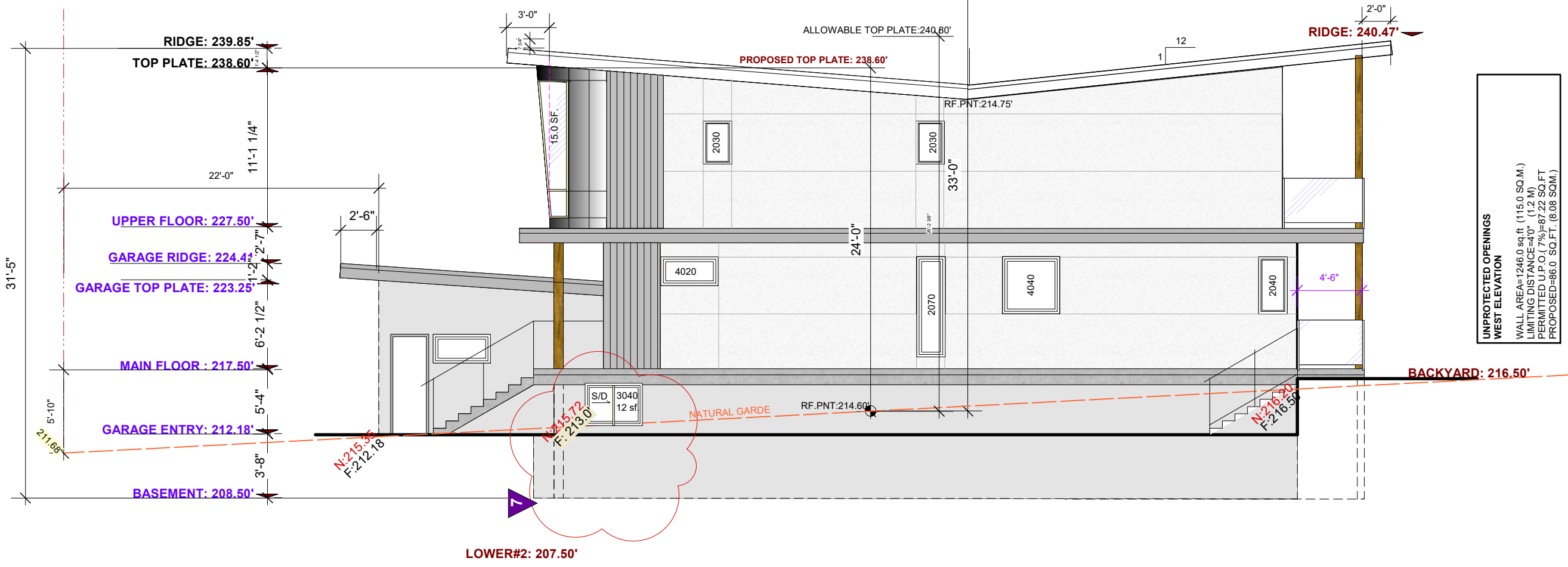

**EAST ELEVATION - HOUSE A**

**UNPROTECTED OPENINGS WEST ELEVATION**  
WALL AREA=1246.0 sq.ft. (115.0 SQ.M.)  
LIMITING DISTANCE=4'0" (1.2 M)  
PERMITTED U.P.O.(7%)=87.22 SQ.FT  
PROPOSED=86.0 SQ.FT. (8.08 SQM.)

**CONSULTANTS:**

**COPYRIGHT:**  
THIS PLAN AND DESIGN ARE AND AT ALL TIMES THE EXCLUSIVE PROPERTY OF VERNACULAR STUDIO INC. AND MAY NOT BE REUSED, REPRODUCED, AND REVISED WITHOUT PRIOR WRITTEN CONSENT.

**GENERAL NOTES:**  
THIS DRAWING MUST NOT BE SCALED. THE GENERAL CONTRACTOR SHALL VERIFY ALL DIMENSIONS AND LEVELS PRIOR TO COMMENCEMENT OF WORK. ALL ERRORS AND OMISSIONS SHALL BE REPORTED IMMEDIATELY TO VERNACULAR STUDIO INC.

**LEGEND:**

F: (FINISHED GRADE)  
E: (EXISTING GRADE)

- ⊙ POWER VENT
- ⊕ FLOOR DRAIN
- ⊗ SMOKE ALARM
- ⊕ FINISHED ELEVATION

**REVISION:**

No.	Issue for	DATE
9		
8		
7	SUBDIV/REZ.	June 14, 2024
6		
5	SUBDIV/REZ.	OCT. 25, 2023
4	SUBDIV/REZ.	AUG. 29, 2023
3	SUBDIV/REZ.	APRIL 06, 2023
2	SUBDIV/REZ.	SEP 23 022
1	PRE-APP.	APRIL 05 2022

**PROJECT:**

**540 WEST 21TH ST. HOUSE 'A'**

**DRAWING TITLE:**

**SIDE ELEVATIONS**

**DATE:**  
JUNE 2019

**DRAWING NO.:**

**DRAWN BY:**  
-G.A.

**CHECKED BY:**  
-M.R.

-R.CH

**SCALE:**1/8

**A-08**



CONSULTANTS:

**COPYRIGHT:**  
THIS PLAN AND DESIGN ARE AND AT ALL TIMES THE EXCLUSIVE PROPERTY OF VERNACULAR STUDIO INC. AND MAY NOT BE REUSED, REPRODUCED, AND REVISED WITHOUT PRIOR WRITTEN CONSENT.

**GENERAL NOTES:**  
THIS DRAWING MUST NOT BE SCALED. THE GENERAL CONTRACTOR SHALL VERIFY ALL DIMENSIONS AND LEVELS PRIOR TO COMMENCEMENT OF WORK. ALL ERRORS AND OMISSIONS SHALL BE REPORTED IMMEDIATELY TO VERNACULAR STUDIO INC.

LEGEND:

F: (FINISHED GRADE)  
E: (EXISTING GRADE)

- POWER VENT
- FLOOR DRAIN
- SMOKE ALARM
- FINISHED ELEVATION

REVISION:

No.	Issue for	DATE
8		
7	SUBDIV/REZ.	June 14, 2024
6		
5	SUBDIV/REZ.	OCT. 25, 2023
4	SUBDIV/REZ.	AUG. 29, 2023
3	SUBDIV/REZ.	APRIL 06, 2023
2	SUBDIV/REZ.	SEP 23, 2022
1	PRE-APP.	APRIL 05 2022

PROJECT:

**540 WEST 21TH ST.  
HOUSE 'B'**

DRAWING TITLE:

**SIDE ELEVATIONS**

DATE:  
JUNE 2019

DRAWING NO.

DRAWN BY:  
-G.A.

CHECKED BY:  
-M.R.

-R.CH

SCALE: 1/8

**A-09**

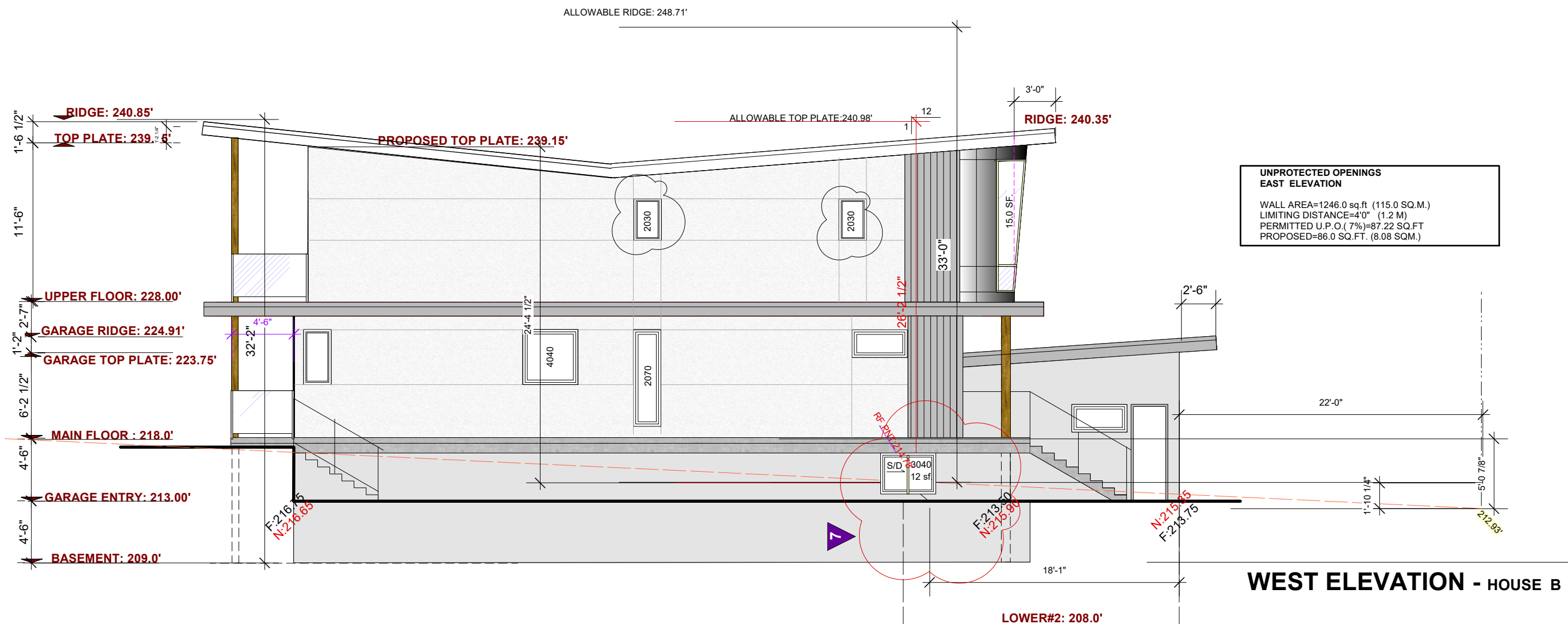

**WEST ELEVATION - HOUSE B**

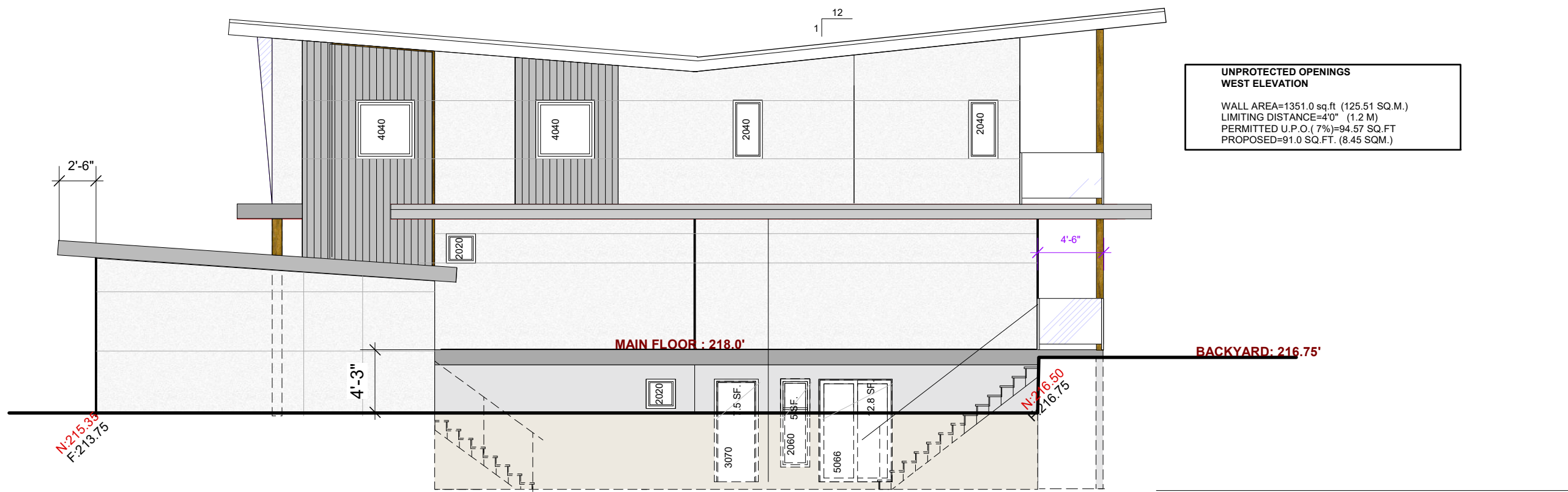

**EAST ELEVATION - HOUSE B**

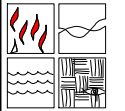

**CONSULTANTS:**

**COPYRIGHT:**  
THIS PLAN AND DESIGN ARE AND AT ALL TIMES THE EXCLUSIVE PROPERTY OF VERNACULAR STUDIO INC. AND MAY NOT BE REUSED, REPRODUCED, AND REVISED WITHOUT PRIOR WRITTEN CONSENT.

**GENERAL NOTES:**  
THIS DRAWING MUST NOT BE SCALED. THE GENERAL CONTRACTOR SHALL VERIFY ALL DIMENSIONS AND LEVELS PRIOR TO COMMENCEMENT OF WORK. ALL ERRORS AND OMISSIONS SHALL BE REPORTED IMMEDIATELY TO VERNACULAR STUDIO INC.

**LEGEND:**

- F: (FINISHED GRADE)
- E: (EXISTING GRADE)
- ⊖ POWER VENT
- ⊕ FLOOR DRAIN
- ⊗ SMOKE ALARM
- ⊙ FINISHED ELEVATION

**REVISION:**

No.	Issue for	DATE
9		
8		
7	SUBDIV/REZ.	June. 14, 2024
6		
5	SUBDIV/REZ.	OCT. 25, 2023
4	SUBDIV/REZ.	AUG. 29, 2023
3	SUBDIV/REZ.	APRIL 06, 2023
2	SUBDIV/REZ.	SEP 23, 2022
1	PRE-APP.	APRIL 05 2022

**PROJECT:**

**540 WEST 21TH ST.  
HOUSE 'A'**

**DRAWING TITLE:**

**BLDG. SECTIONS**

**DATE:**

JUNE 2019

**DRAWING NO.:**

**DRAWN BY:**  
-G.A.

**CHECKED BY:**  
-M.R.

-R.CH

**SCALE:** 1/8

**A-10**

**SECTION BB - HOUSE A**

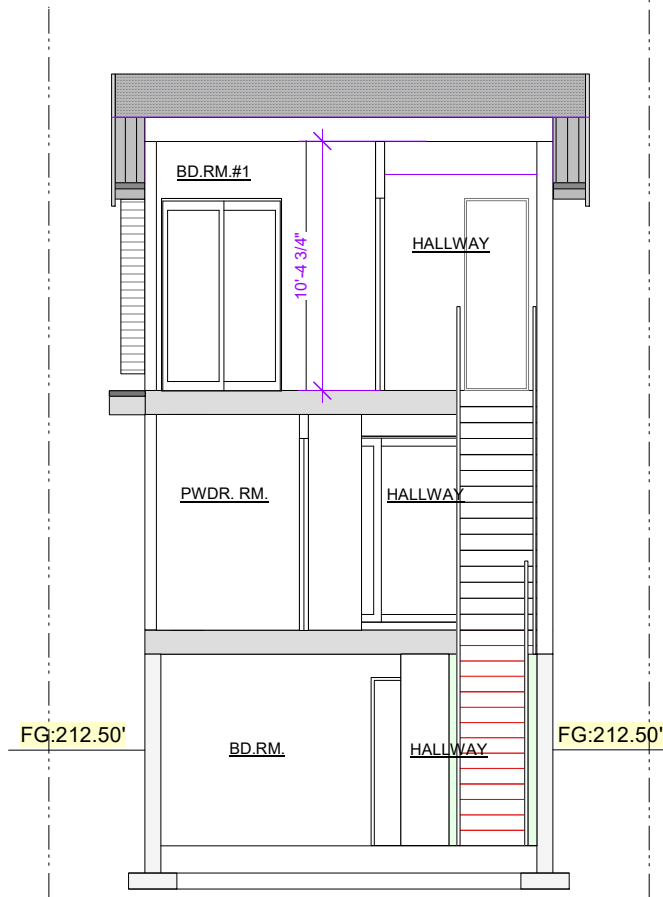

**HEIGHT CALCULATION  
HOUSE # A**

**FRONT AVE. GARDE:**  $211.23+212.14/2=211.68'$   
**REAR AVE. GARDE:**  $218.65+219.35/2=219.00'$   
**REFFRENECE POINT:**  $211.68+(219.0- 211.68)X0.4$   
**=214.60**

**ALLOWABLE TOP PLATE:**  $214.60 + 26.2'=240.80'$   
**ALLOWABLE HEIGHT:**  $214.60 + 33'= 247.60'$

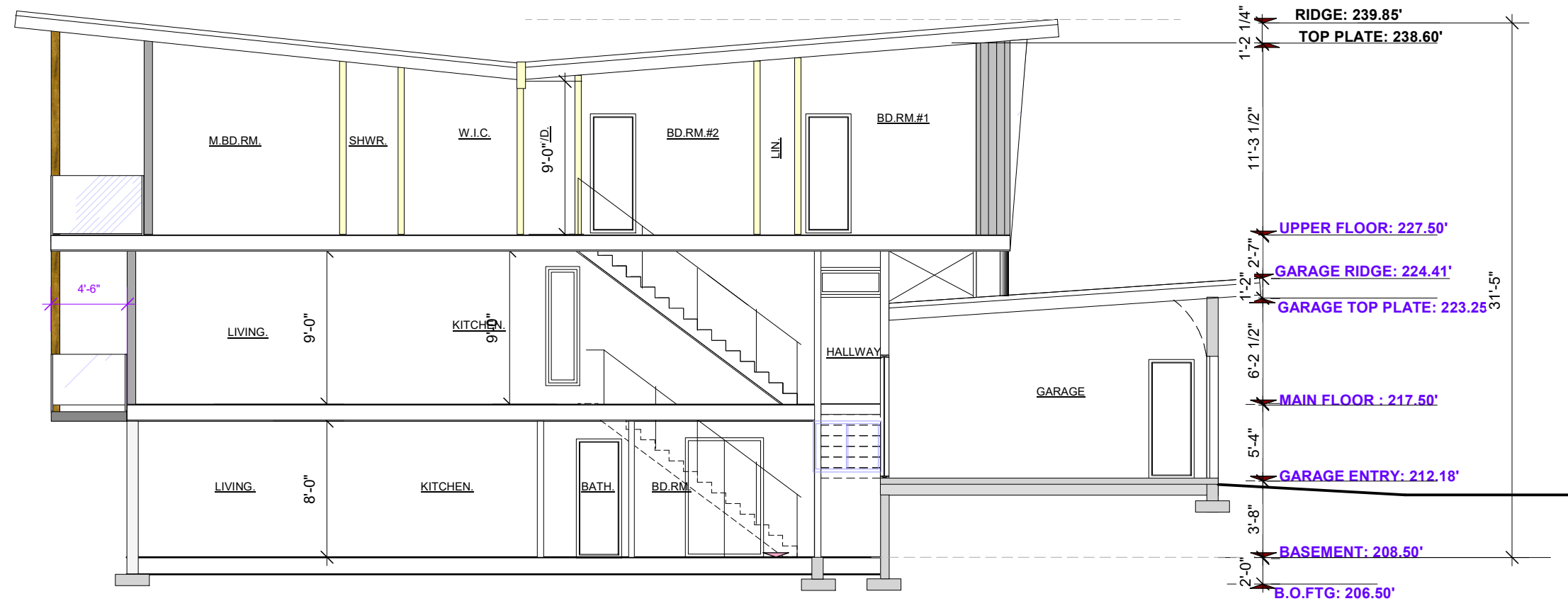

**SECTION AA - HOUSE A**



CONSULTANTS:

COPYRIGHT:  
THIS PLAN AND DESIGN ARE AND AT ALL TIMES  
THE EXCLUSIVE PROPERTY OF VERNACULAR  
STUDIO INC. AND MAY NOT BE REUSED,  
REPRODUCED, AND REVISED WITHOUT  
PRIOR WRITTEN CONSENT.

GENERAL NOTES:  
THIS DRAWING MUST NOT BE SCALED. THE  
GENERAL CONTRACTOR SHALL VERIFY ALL  
DIMENSIONS AND LEVELS PRIOR TO  
COMMENCEMENT OF WORK. ALL  
ERRORS AND OMISSIONS SHALL BE REPORTED  
IMMEDIATELY TO VERNACULAR STUDIO INC.

LEGEND:

F: (FINISHED GRADE)  
E: (EXISTING GRADE)

- POWER VENT
- FLOOR DRAIN
- SMOKE ALARM
- FINISHED ELEVATION

REVISION:

No.	Issue for	DATE
9		
8		
7	SUBDIV/REZ.	June 14, 2024
6		
5	SUBDIV/REZ.	OCT. 25, 2023
4	SUBDIV/REZ.	AUG. 29, 2023
3	SUBDIV/REZ.	APRIL 05, 2023
2	SUBDIV/REZ.	SEP 23, 2022
1	PRE-APP.	APRIL 05 2022

PROJECT:  
**540  
WEST 21TH ST.  
HOUSE 'B'**

DRAWING TITLE:  
**BUILDING SECTIONS**

DATE:  
JUNE 2019

DRAWING NO.:

DRAWN BY :  
-G.A.  
CHECKED BY:  
-M.R.  
-R.CH  
SCALE: 1/8

**A-11**

**SECTION BB - HOUSE B**

**HEIGHT CALCULATION  
HOUSE B**

**FRONT AVE. GARDE:**  $212.14+213.73/2=212.93'$   
**REAR AVE. GARDE:**  $219.35+219.71/2=219.53'$   
**REFFRENECE POINT:**  $212.14+(219.53- 212.93')\times 0.4$   
=214.78

**ALLOWABLE TOP PLATE:**  $214.78 + 26.2'=240.98'$   
**ALLOWABLE HEIGHT:**  $214.78 + 33'= 247.78'$

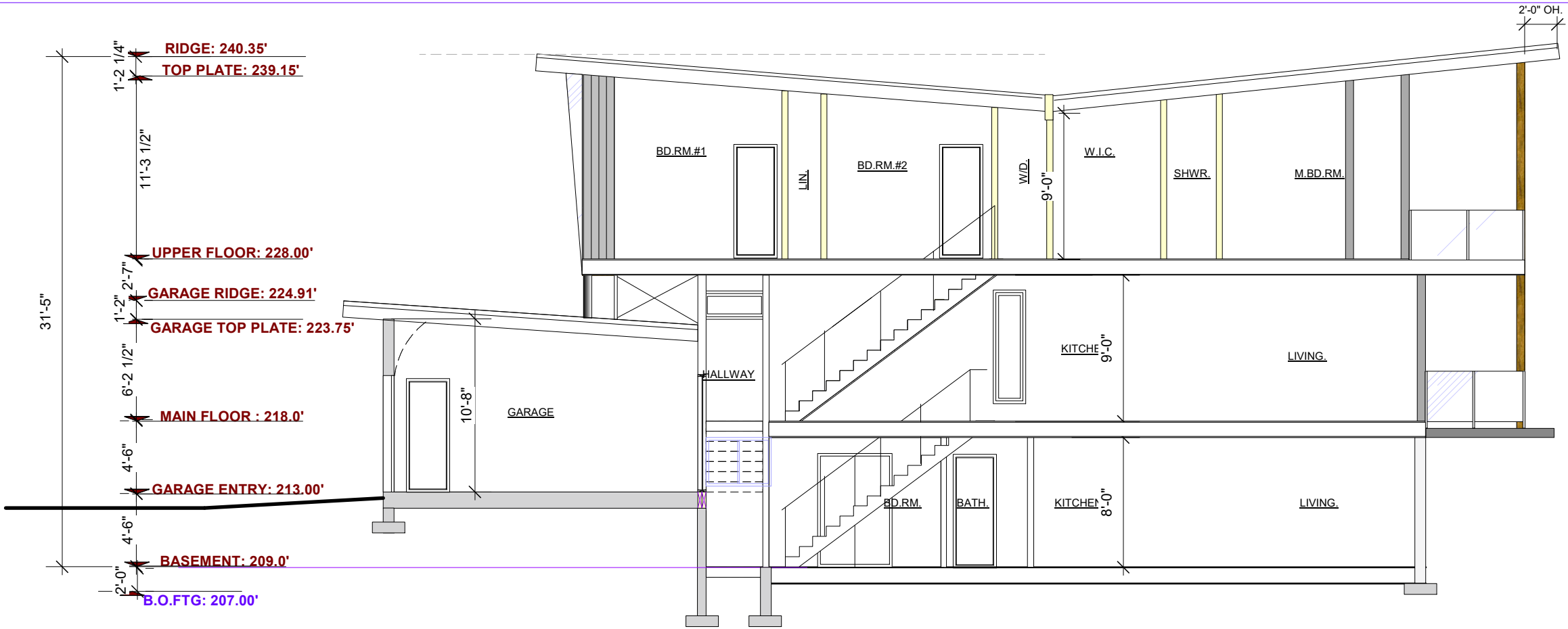
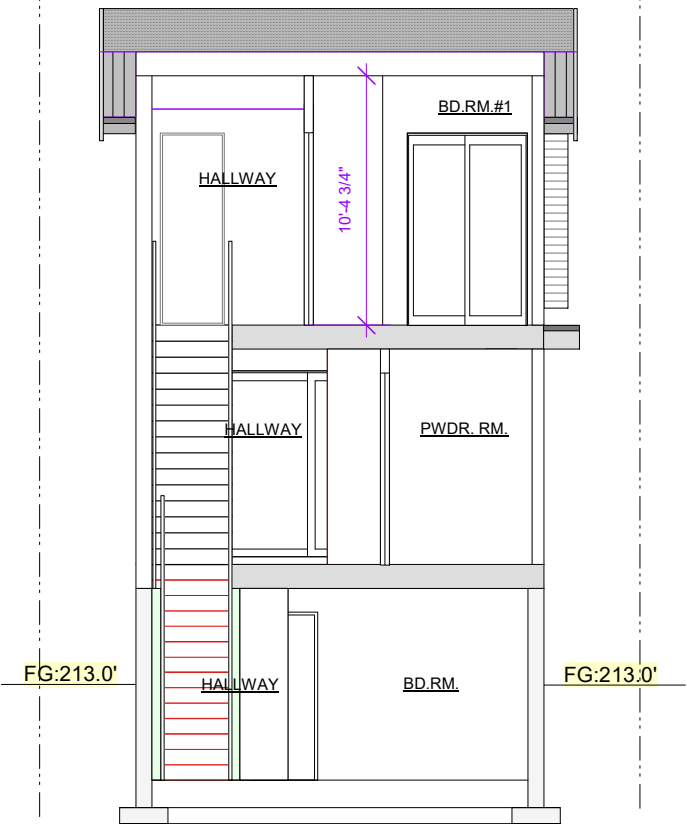

**SECTION AA - HOUSE B**

**CONSULTANTS:**

**COPYRIGHT:**  
THIS PLAN AND DESIGN ARE AND AT ALL TIMES THE EXCLUSIVE PROPERTY OF VERNACULAR STUDIO INC. AND MAY NOT BE REPRODUCED, REPRODUCED, AND REVISED WITHOUT PRIOR WRITTEN CONSENT.

**GENERAL NOTES:**  
THIS DRAWING MUST NOT BE SCALED. THE GENERAL CONTRACTOR SHALL VERIFY ALL DIMENSIONS AND LEVELS PRIOR TO COMMENCEMENT OF WORK. ALL ERRORS AND OMISSIONS SHALL BE REPORTED IMMEDIATELY TO VERNACULAR STUDIO INC.

**LEGEND:**

F: (FINISHED GRADE)  
E: (EXISTING GRADE)

⊙ POWER VENT

⊕ FLOOR DRAIN

⊗ SMOKE ALARM

⊙ FINISHED ELEVATION



**REVISION:**

No.	Issue for	DATE
9		
8		
7	SUBDIV/REZ.	June 14, 2024
6	SUBDIV/REZ.	FEB. 07, 2024
5	SUBDIV/REZ.	OCT. 26, 2023
4	SUBDIV/REZ.	AUG. 29, 2023
3	SUBDIV/REZ.	APRIL 06, 2023
2	SUBDIV/REZ.	SEP 23, 2022
1	PRE-APP.	APRIL 05 2022

**PROJECT:**

**540  
WEST 21TH ST.**

**DRAWING TITLE:**

**ACCESSORY BUILDING (A&B)**

**DATE:**  
JUNE 2019

**DRAWING NO.:**

**DRAWN BY:**  
-G.A.

**CHECKED BY:**  
-M.R.

-R.CH

**SCALE:** 1/8

**A-12**

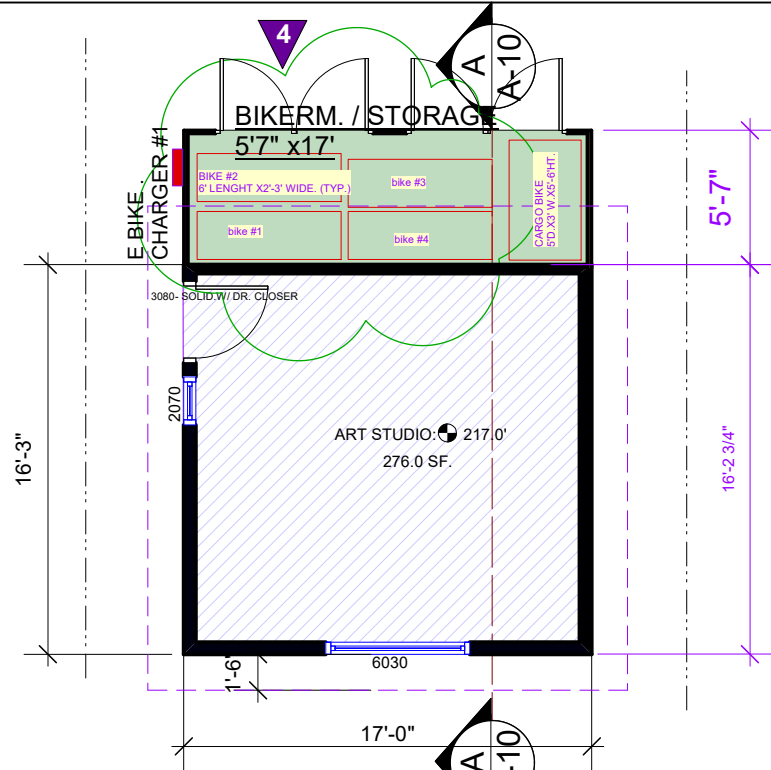

**ACCESSORY BUILDING 'A'**

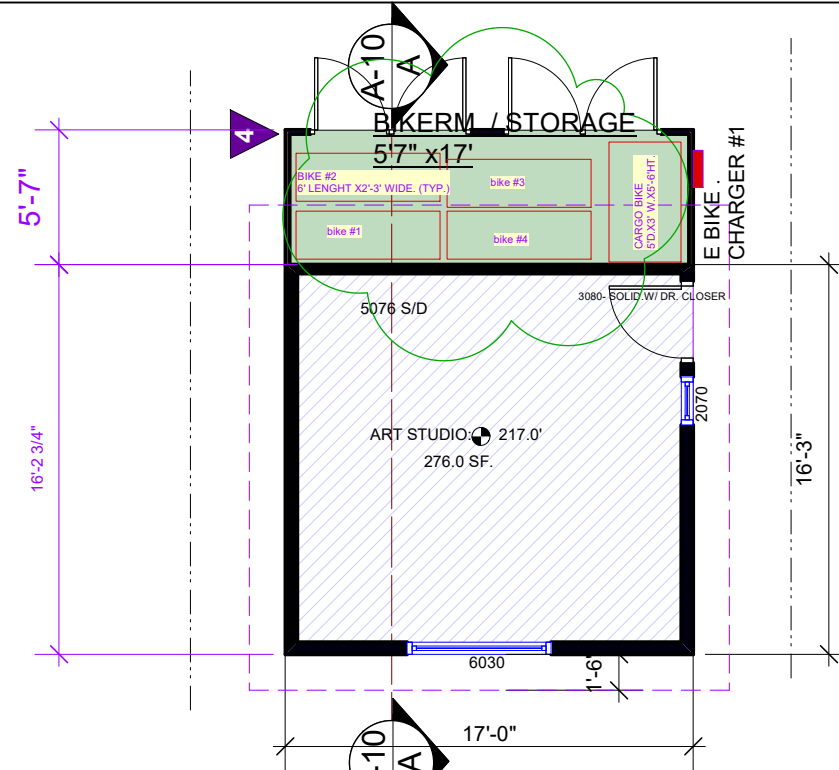

**ACCESSORY BUILDING 'B'**

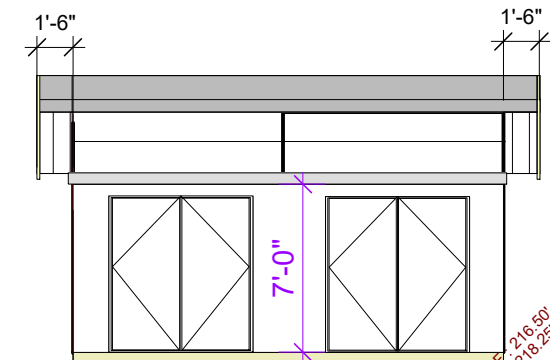

**NORTH ELEVATION**

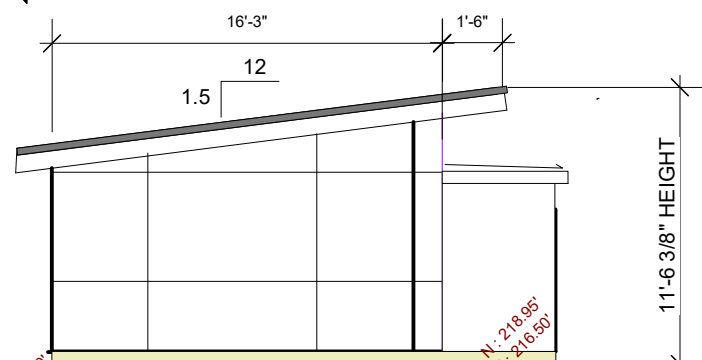

**EAST ELEVATION**

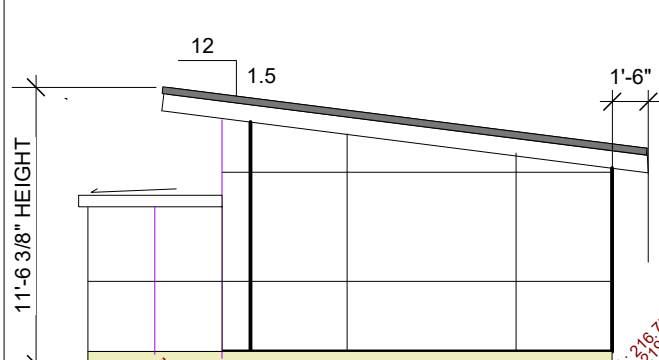

**WEST ELEVATION**

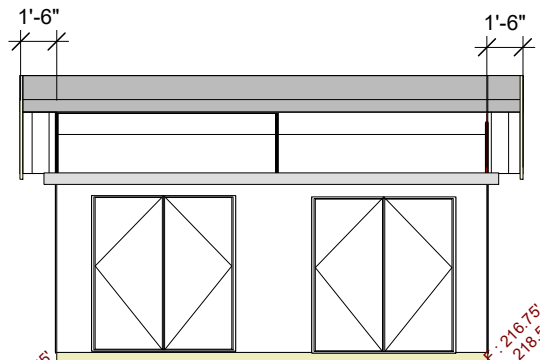

**NORTH ELEVATION**

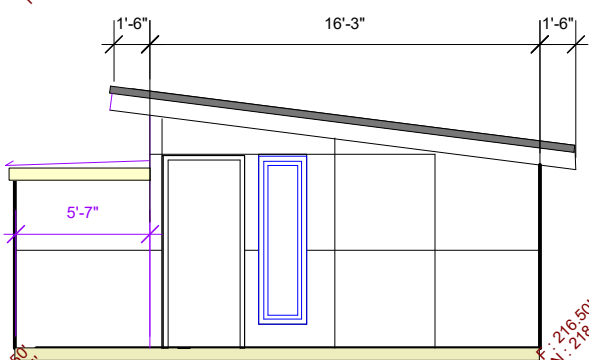

**WEST ELEVATION**

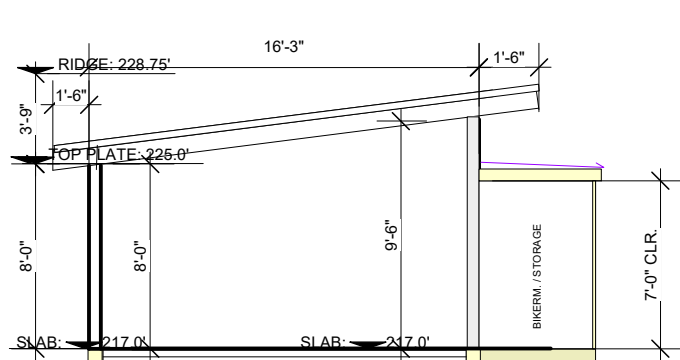

**SECTION AA**

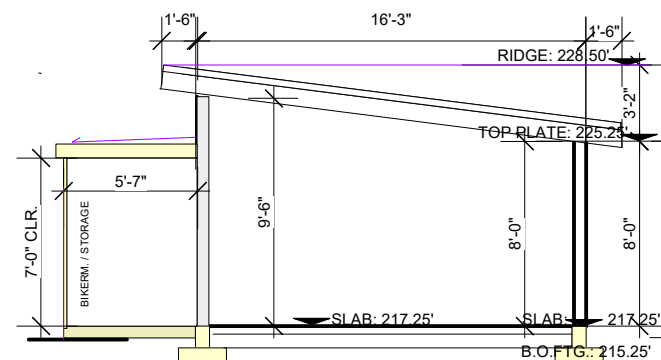

**SECTION AA**

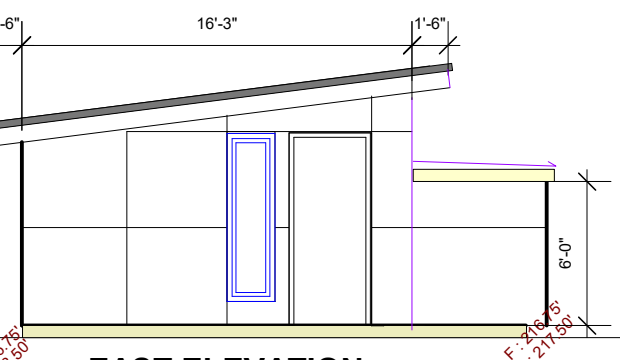

**EAST ELEVATION**

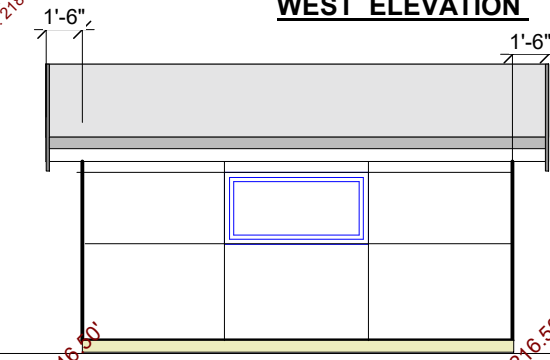

**SOUTH ELEVATION**

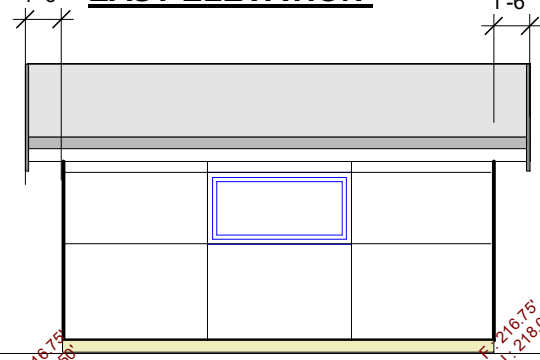

**SOUTH ELEVATION**